

sludge storage/ buffer

SBR reactor

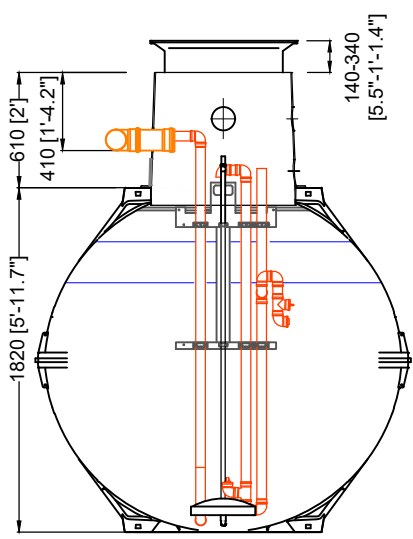

section SBR reactor

TD - Mini (as option)

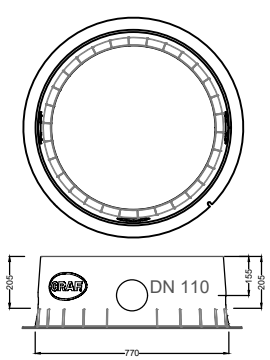

<p>D</p> <p>Klaro E Professional 16 EW TD-Maxi +P 2 x Carat 4800 L / 2 x 1268 gal.</p>			<p>Artikel-Nr. product no. article no. artículo no.</p> <p>107497</p>
<p>GB Klaro E Professional 16 inh. TD-Maxi +P 2 x Carat 4800 L / 2 x 1268 gal.</p>	<p>ES Klaro E Professional 16 PE Cúpula Maxi +P 2 x Carat 4800 L / 2 x 1268 gal.</p>	<p>FR Klaro E Professional 16 EH Maxi-dôme +P 2 x Carat 4800 L / 2 x 1268 gal.</p>	<p>revision</p>
<p>gezeichnet drawn</p> <p>ISC</p>	<p>Gewicht weight</p> <p>2 x 220 kg</p>	<p>Otto Graf GmbH Carl-Zeiss-Str. 2-6 DE-79331 Teningen mail@graf.info www.graf.info</p>	
<p>Datum date</p> <p>2021.07.08</p>	<p>Toleranz tolerance</p> <p>+/- 3%</p>		
<p>Maßstab scale</p> <p>M 1:40 / 1:30</p>	<p>Einheiten units</p> <p>mm [inch] gal. = US gal.</p>		